

LIMITED WARRANTY

Products manufactured by GRUNDFOS are warranted to the original user only to be free of defects in material and workmanship for a period of 18 months from date of installation, but not more than 24 months from date of manufacture. GRUNDFOS' liability under this warranty shall be limited to repairing or replacing at GRUNDFOS' option, without charge, F.O.B. GRUNDFOS factory or authorized service station, any product of GRUNDFOS manufacture. GRUNDFOS will not be liable for any costs of removal, installation, transportation, or any other charges which may arise in connection with a warranty claim. Products which are sold but not manufactured by GRUNDFOS are subject to the warranty provided by the manufacturer of said products and not by GRUNDFOS' warranty. GRUNDFOS will not be liable for damage or wear to products caused by abnormal operating conditions, accident, abuse, misuse, unauthorized alteration or repair, or if the product was not installed in accordance with GRUNDFOS printed installation and operating instructions.

To obtain service under this warranty, the defective product must be returned to the distributor or dealer of GRUNDFOS products from which it was purchased together with proof of purchase and installation date, failure date, and supporting installation data. Unless otherwise provided, the distributor or dealer will contact GRUNDFOS or an authorized service station for instructions. Any defective product to be returned to GRUNDFOS or a service station must be sent freight prepaid; documentation supporting the warranty claim and/or a Return Material Authorization must be included if so instructed.

MANUFACTURER WILL NOT BE LIABLE FOR ANY INCIDENTAL OR CONSEQUENTIAL DAMAGES, LOSSES, OR EXPENSES ARISING FROM INSTALLATION, USE, OR ANY OTHER CAUSES. THERE ARE NO EXPRESS OR IMPLIED WARRANTIES, INCLUDING MERCHANTABILITY OR FITNESS FOR A PARTICULAR PURPOSE, WHICH EXTEND BEYOND THOSE WARRANTIES DESCRIBED OR REFERRED TO ABOVE. EXCEPT AS EXPRESSLY HEREIN PROVIDED THE GOODS ARE SOLD "AS IS", THE ENTIRE RISK AS TO QUALITY AND FITNESS FOR A PARTICULAR PURPOSE, AND PERFORMANCE OF THE GOODS IS WITH THE BUYER, AND SHOULD THE GOODS PROVE DEFECTIVE FOLLOWING THEIR PURCHASE, THE BUYER AND NOT THE MANUFACTURER, DISTRIBUTOR, OR RETAILER ASSUMES THE ENTIRE RISK OF ALL NECESSARY SERVICING OR REPAIR.

Some jurisdictions do not allow the exclusion or limitation of implied warranties of merchantability and fitness for a particular purpose, of incidental or consequential damages and some jurisdictions do not allow limitations on how long implied warranties may last or require you to pay certain expenses as set forth above. Therefore, the above limitations or exclusions may not apply to you. This warranty gives you specific legal rights and you may also have other rights which vary from jurisdiction to jurisdiction.

The telephone number of our service and repair facilities central directory, from which you can obtain the locations of our service and repair facilities is, 1-800-333-1366.

Federal Communications Commission Notice:

This equipment has been tested and found to comply with the limits for a Class A digital device, pursuant to part 15 of the FCC Rules. These limits are designed to provide reasonable protection against harmful interference when the equipment is operated in a commercial environment. This equipment generates, uses, and can radiate radio frequency energy and, if not installed and used in accordance with the instruction manual, may cause harmful interference to radio communications. Operation of this equipment in a residential area is likely to cause harmful interference in which case the user will be required to correct the interference at his own expense.

GRUNDFOS®



Leaders in Pump Technology

Grundfos Pumps Corporation • 3131 N. Business Park Ave., Fresno, CA 93727

Customer Service Centers: Allentown, PA • Fresno, CA

Phone: (800) 333-1366 • Fax: (800) 333-1363

Canada: Oakville, Ontario • Mexico: Apodaca, N.L.

Visit our website at www.us.grundfos.com

L-RF-IO-008 Rev.2/00
PRINTED IN USA

Redi-Flo3

SQE-NE

Environmental Pumps

Installation and Operating Instructions



- **Efficient Permanent Magnet Motor**
- **High Starting Torque**
- **Soft Start**
(2 seconds to reach maximum rpm, and maximum pressure)
- **Built-in "Smart" Motor Protection with automatic restart**
- **Communication Through the Redi-Flo3 Status Box**
- **Integrated Protection Against Adverse Conditions**
- **Environmental Materials of Construction**

Please leave these instructions with the pump for future reference

GRUNDFOS®



Leaders in Pump Technology

SAFETY WARNING

Electrical Work

WARNING: To reduce the risk of electric shock during operation of this pump requires the provision of acceptable grounding. If the means of connection to the supply connected box is other than grounded metal conduit, ground the pump back to the service by connecting a copper conductor (at least the size of the circuit supplying the pump) to the grounding screw provided within the wiring compartment.

Pre-Installation Checklist

1. Well Preparation

If the pump is to be installed in a new well then the well should be fully developed and bailed or blown free of cuttings and sand. The construction of the GRUNDFOS Redi-Flo3 submersibles makes it resistant to abrasion; however, no pump made of any material can forever withstand the destructive wear that occurs when constantly pumping sandy water.

2. Make Sure You Have the Right Pump

Determine the maximum depth of the well, and the drawdown level at the pump's maximum capacity. Pump selection and setting depth should be made based on this data.

3. Pumped Fluid Requirements

Submersible well pumps are designed for pumping turbid free, cool water; free of air or gases. Possible decreased pump performance and life expectancy can occur when operating in conditions outside of this chemistry. Water temperature ideally should not exceed 104°F. Extended pump life and optimal performance can best be obtained through proper well development and in the case of higher fluid temperatures use a cooling shroud.

A check should be made to ensure that the installation depth of the pump will always be at least three feet below the maximum drawdown level of the well (Fig.1). The bottom of the motor should never be installed lower than the bottom of the screen.

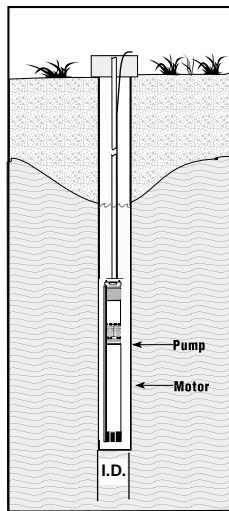

Fig. 1

4. Motor Cooling Requirements

To ensure proper motor cooling refer to the table below for minimum flow requirements:

Flow velocity past the motor	Maximum liquid temperature
0.0 f/s (free convection)	86° F(30°C)
Min. 0.5 f/s	104°F (40°C)

Pre-Installation Checklist

If the pump is to be installed horizontally, e.g. in a tank, and there is a risk that the pump might be covered by mud, it must be installed in a flow sleeve.

Liquid temperatures/cooling

Figure 2 shows an operating Redi-Flo3 pump installed in a well.

Figure 2 illustrates the following:

- Well diameter.
- Pump diameter.
- Temperature of pumped liquid.
- Flow past the motor to the pump strainer.

Note: The well diameter must be at least 3". If there is a risk that the motor will be covered with sediment or the pumped fluid is at an elevated temperature then it is recommended the pump be placed in a Flow Sleeve. The motor should always be installed above the well screen.

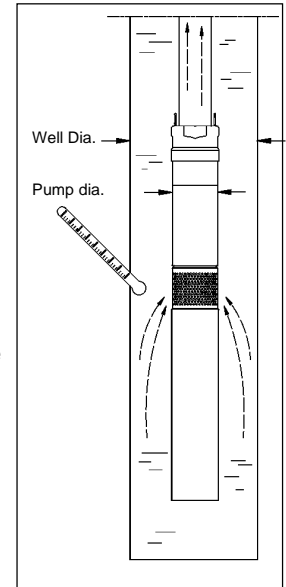

Fig. 2

5. Applications

Typical applications:

Environmental applications such as:

- Remediation pumping.
- Leachate recovery.
- Pollution recovery.
- Dewatering

6. Motor Preparation

GRUNDFOS MSE3-NE submersible motors have water-lubricated slide bearings. No additional lubrication is required.

The submersible motors are factory-filled with a special GRUNDFOS motor liquid (type SML 2), which will protect the motor fluid down to -4°F(20°C) and to prevent the growth of bacteria. The level of motor fluid is important for the operating life of the bearings and consequently the life of the motor.

Refilling of motor liquid

It is recommended to check and if needed, refill the motor with GRUNDFOS motor fluid SML 2.

Pre-Installation Checklist

To refill the motor, proceed as follows:

1. Remove the cable guard and separate the pump end from the motor.
2. Place the motor in vertical position with an inclination of approx. 10°.
3. Remove the filling plug using a screwdriver or a similar tool.
4. Inject motor liquid into the motor with a filling syringe or similar tool, see fig. 3.
5. To allow possible air to escape, move the motor from side to side. And turn the shaft.
6. Replace the filling plug and make sure it is tight.
7. Assemble pump end and motor.
8. Install the cable guard.

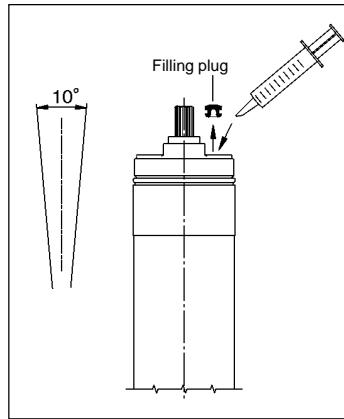

Fig. 3

The pump is now ready for installation.

7. Installation Postions

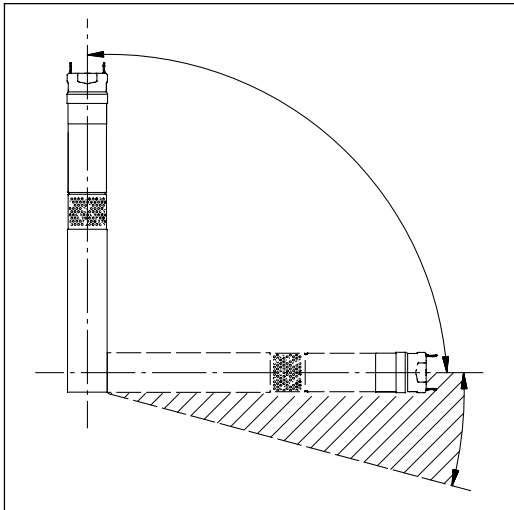

Fig. 4

Positional requirements

The pump is suitable for vertical as well as horizontal installation, however, the pump shaft must never fall below the horizontal plane, see fig. 4.

Installation Procedures

8. Electrical connection

General

The electrical connection should be carried out by an authorized electrician in accordance with local regulations.



Before starting work on the pump, make sure the electricity supply has been switched off and that it cannot be accidentally switched on. The pump must be grounded. The pump must be connected to an external mains switch.

The supply voltage, rated maximum current and power factor (PF) appear on the motor nameplate. The required voltage for GRUNDFOS submersible MSE3-NE motors, measured at the motor terminals, is +6%/-10% of the nominal voltage during continuous operation (including variation in the supply voltage and losses in cables).

If the pump is connected to an installation where a Ground Fault circuit breaker (GFI) is used as additional protection, this circuit breaker must trip out when ground fault currents with DC content (pulsating DC) occur.

Supply voltage: 1 x 100-115V or 1 x 200-240 V +6%/-10%, 50/60 Hz.

The current consumption can only accurately be measured by means of a true RMS instrument. If other instruments are used, the value measured will differ from the actual value.

The Redi-Flo3 pumps can be connected to a Redi-Flo3 status box.

Note: The pump must never be connected to a capacitor or to another type of control box other than a Redi-Flo3 status box. The pump must never be connected to an external frequency converter.

Motor protection

The motor has built-in automatic thermal overload protection and requires no additional motor protection.

Connection of motor

The motor can be connected directly to the main circuit breaker.

Installation Procedures

9. Making the Wiring Connections

WARNING!

To reduce the risk of electric shock during operation of this pump requires the provision of acceptable grounding. If the means of connection to the supply connected box is other than grounded metal conduit, ground the pump back to the service by connecting a copper conductor, at least the size of the circuit supplying the pump.

Single-Phase 2-wire Wiring Diagram for GRUNDFOS Motors

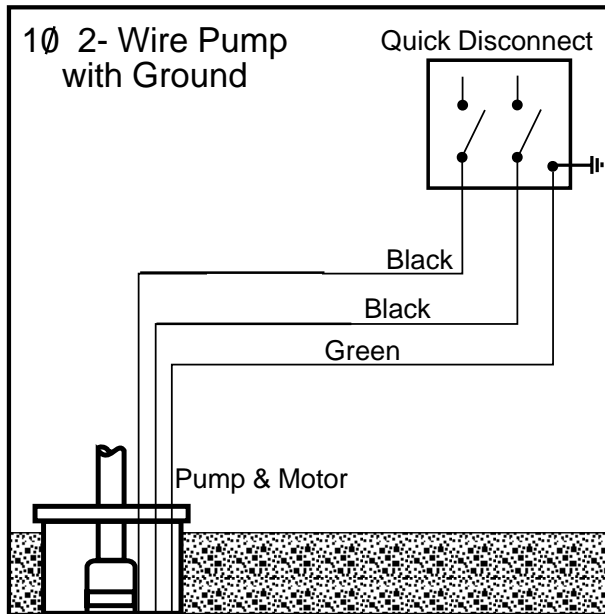

A capacitor or control box should NEVER be connected to a Redi-Flo3 submersible pump.

Fig. 5

Installation Procedures

10. Cable Sizing

SINGLE-PHASE 60 HZ Maximum Cable Length Motor Service to Entrance

Motor Rating		Copper Wire Size								
VOLTS	HP	14	12	10	8	6	4	2	0	00
115	1/3	130	210	340	540	840	1300	1960	2910	
	1/2	100	160	250	390	620	960	1460	2160	
230	1/3	550	880	1390	2190	3400	5250	7960		
	1/2	400	650	1020	1610	2510	3880	5880		
	3/4	300	480	760	1200	1870	2890	4370	6470	
	1	250	400	630	990	1540	2380	3610	5360	6520
	1 1/2	190	310	480	770	1200	1870	2850	4280	5240

11. Motor Cable

Redi-Flo3 pumps are specifically designed to be used with Grundfos SQE-NE Tefzel motor leads. Standard SQE-NE Tefzel motor leads are available between 25 and 300 foot lengths in 5 foot increments. Custom lengths longer than 300 feet are available in 10 foot increments up to 600 feet from the factory.

Installation Procedures

General

Note: Do not lower or lift the pump by means of the motor cable.

The loose data plate supplied with the pump should be placed close to the installation site.

12. Installing the cable plug to the motor

To install the cable plug, proceed as follows:

1. Check that the cable is of the correct type, cross-section and length.
2. Check that the mains on the location has correct connection to ground.
3. Check that the motor socket is clean and dry.
4. Press the cable plug into the motor socket.

The plug will only fit one way, see fig. 6.

5. Install and tighten the four nuts, see fig. 6.

When the plug has been installed, there must not be a clearance between the motor and the cable plug.

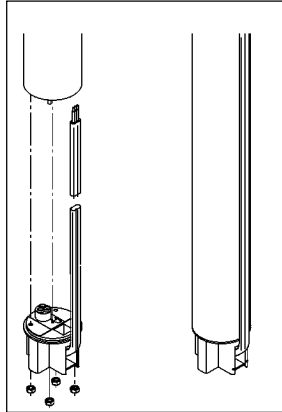

Fig. 6

13. Installing the cable guard

To fit the cable guard, proceed as follows:

1. Make sure that the motor lead lies flat in the cable guard.
2. The two flaps of the cable guard must engage with the upper edge of the pump sleeve, see fig. 7.

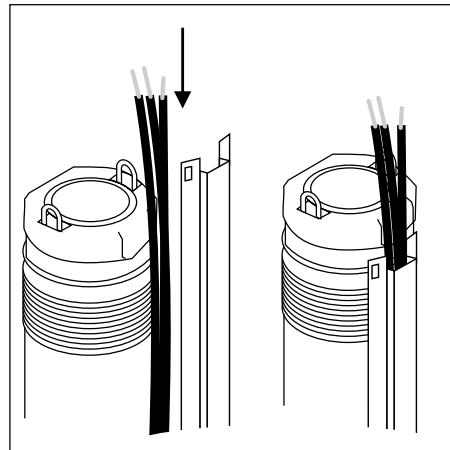

Fig. 7

3. Fasten the cable guard to the cable plug with the four screws supplied, see fig. 8.

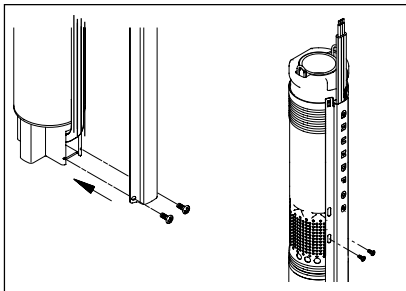

Fig. 8

Installation Procedures

14. Piping

- The pump should only be gripped by the two flats at the top of the pump, as shown in fig. 9.
- The pump can be installed vertically or horizontally. During operation, the pump must always be completely submerged in water.
- When plastic pipe is used, a stainless steel safety wire is recommended for lowering and lifting the pump. Fasten the wire to the eyelet on the pump, as shown in fig. 10.
- The threaded joints must be well cut and fit together tightly to ensure that they do not work loose.

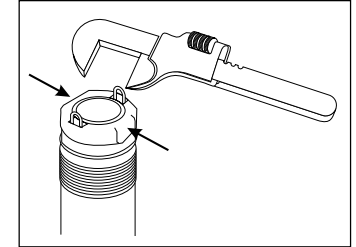

Fig. 9

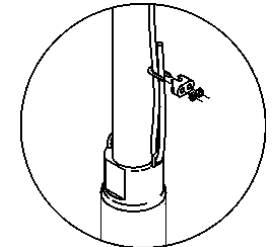

Fig. 10

15. Installing the Pump

Installation Depth

The dynamic water level should always be above the pump see fig. 11.

- A = Dynamic water level
- B = Static Water Level
- C = Minimum 3" well diameter
- D = Drawdown
- E = Installation depth below static water level. Maximum 500 feet

Procedures

To install the pump, follow these steps:

1. Install the enclosed data plate sticker at the well head.
2. Check the well for proper clearance — the well must be at least 3" in diameter. It is a good idea to check the well for clearance using a plumb ring (2.95 ϕ x 10 in.).
3. Attach the first section of riser pipe to the pump.

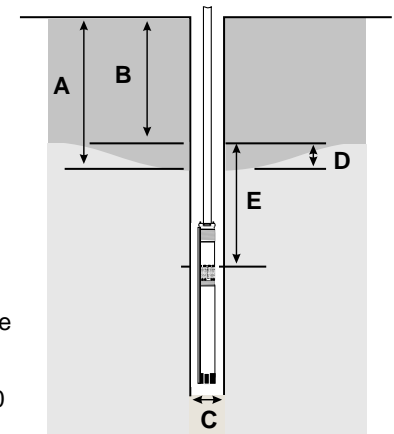

Fig. 11

16. Installing the Pump(cont.)

4. Lower the pump into the well. Make sure the motor cable is not damaged when the pump is lifted or lowered into the well — especially in 3" wells. **NOTE: Do not lower or lift the pump using the motor cable.**
5. When the pump has been installed to the required depth, the installation should be finished by means of a well seal. Note that the dynamic water level should always be above the pump.
6. Loosen the safety wire so that it becomes unloaded and lock it to the well seal using a cable clamp.
7. Attach the supplemental information label at the electrical installation site.
8. Complete the electrical connections. **Remember that a capacitor or a control box should NEVER be connected to a Redi-Flo3 submersible pump.**

Installation depths

Maximum installation depth: below the static water level: 500 feet,
 Minimum installation depths: 1.75' below the dynamic water level:

Vertical installation:

During start-up and operation, the pump must always be completely submerged in water.

Horizontal installation:

The pump must be installed at least 1.75 ft. below the dynamic water level. If there is a risk that the pump might be covered by mud, the pump must always be placed in a flow sleeve.

17. Generator Operation

- It is OK to operate the Redi-Flo3 with a generator.

The generator must be sized 10% above the pumps P1 (Input Power) values.
 Use the table to select the correct size generator for the motor HP.

Motor HP	Min. Generator Size (Watts)
1/3 - 1/2 A	1000
1/2 - 3/4 B	1700
1- 1½ C	2000

18. Starting the Pump for the First Time

When the pump has been connected correctly, the pump should be started with the discharge valve closed approximately one-third. Due to the soft start feature, the pump takes approximately 2 seconds to develop full pressure.

Motor Cooling and Other Considerations

- Make sure the well is capable of yielding a minimum quantity of water corresponding to the pump capacity.
- Do not start the pump until it is completely submerged in the liquid.
- As the valve is being opened, the drawdown should be checked to ensure that the pump always remains submerged.
- To ensure the necessary cooling of the motor, the pump should never be set so low that it gives no water. If the flow rate suddenly falls, the reason might be that the pump is pumping more water than the well can yield.

Water Impurities

- If there are impurities in the water, the valve should be opened gradually as the water becomes clearer. The pump should not be stopped until the water is clean, otherwise the pump parts and the check valve may become clogged.
- When the water is clean the valve should be fully opened.

Minimum flow rate

- To ensure the necessary cooling of the motor, the pump flow rate should never be set to a value lower than .2 gpm. If the flow rate suddenly falls, the reason might be that the pump is pumping more water than the well can yield.

Note: The pump's dry-running protection is effective only within the recommended duty range of the pump.

Note: Do not let the pump run against a closed discharge valve for more than 5 minutes. When the discharge valve is closed, there is no cooling flow and there is a risk of overheating in motor and pump.

Operating the Pump

Built-in protection

The motor incorporates an electronic unit which protects the motor in various damaging situations.

In case of overload, the built-in overload protection will stop the pump for 5 minutes. After 5 minutes, the pump will attempt to restart.

If the pump is started and the well has not recovered, the pump will stop after 30 seconds.

If the pump has been stopped as a result of dry running, it will start automatically after 5 minutes or the reset time set by the R100.

Resetting the pump:

Switch off the electricity supply for 1 minute.

The motor is protected against the following conditions:

- dry running,
- voltage surges (up to 5000 V),
- overvoltage,
- undervoltage,
- overload
- overtemperature.

MSE 3NE Motors:

Note: To set Dry-Run limit in the MSE-NE pumps, you need to connect the pump to a Redi-Flo3 status box. Refer to Redi-Flo3 status box I&O for proper connections.

To set Dry-Run protection, follow these steps:

1. Start the pump against closed discharge.
2. Rapidly read the power consumption value (W) in the R100 display 2.5.
3. Multiply this value by 0.9.
4. Within the R100, go to display 4.6 and enter the new value (minimum power limit).
5. Go to display 4.7 and change the setting to "Active".

For further information on dry-running, refer to RediFlo3 Status Box I&O.

Maintenance and service:

The pumps are normally maintenance-free. Deposits and wear may occur. For that purpose, service kits and service tools are available from GRUNDFOS. The GRUNDFOS Service Manual is available on request. The pumps can be serviced at a GRUNDFOS service center.

Assembly/Disassembly

19. Assembly of Pump and Motor

To assemble pump end and motor, proceed as follows:

1. Place the motor horizontally in a vice and tighten it, see fig. 12.
2. Grease the motor shaft end with a vegetable based grease.
3. Screw the pump end on the motor. A spanner may be used on the clamping faces of the pump part, see fig.12.
4. Install cable guard as described on page 7.

When pump end and motor have been assembled correctly, there must not be a clearance between pump end and motor.

To disassemble reverse procedure.

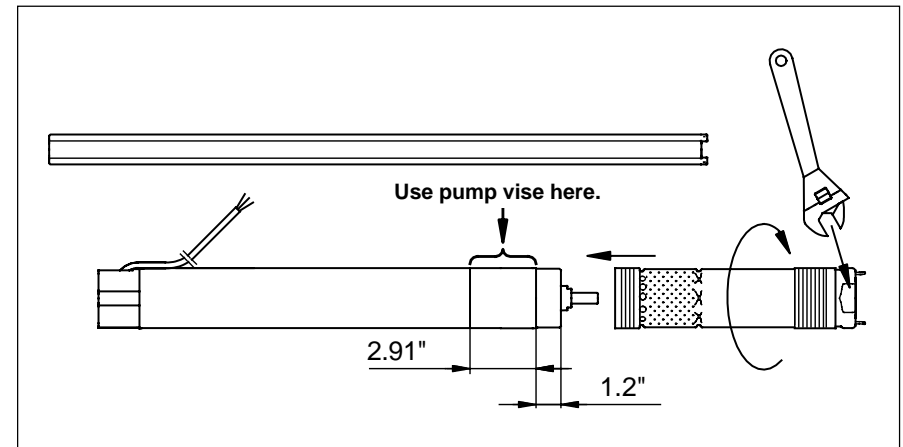

Fig. 12

Fault	Cause	Remedy
1. The pump does not run	a. The fuses are blown	Replace the blown fuses. If the new fuses blow too, check the electrical installation and the drop cable.
	b. The GFI circuit breaker has tripped.	Reset the circuit breaker.
	c. No electricity supply.	Contact the Electricity provider.
	d. The motor protection has cut off the electricity supply due to overload.	Check for motor/pump blockage.
	e. The drop cable is defective.	Repair/replace the pump/cable.
	f. Overvoltage has occurred.	Check the electricity supply
2. The pump runs but gives no water.	a. The discharge is closed.	Open the valve
	b. No water or too low water level in well.	See item 3a.
	c. Check valve is stuck in it's closed position.	Pull the pump and clean or replace the valve.
	d. The suction strainer is closed.	Pull the pump and clean the strainer.
	e. The pump is defective.	Repair/replace the pump.
3. The pump runs at reduced capacity.	a. The drawdown is larger than anticipated.	Increase the installation depth of the pump, throttle the pump or replace it with a smaller capacity model.
	b. The valve s in the discharge pipe are partly closed/blocked.	Check and clean/replace the valves as necessary.
	c. The discharge pipe is partly choked by impurities (Iron bacteria).	Clean/replace the discharge pipe.
	d. The non- return valve of the pump is blocked.	Pull the pump and check/replace the valve.
	e. The pump and the riser pipe are partly choked by impurities (Iron bacteria).	Pull out the pump. Check and clean or replace the pump, if necessary. Clean the pipes.
	f. The pump is defective.	Repair/replace the pump.
	g. Hole in discharge pipe.	Check and repair the piping.
	h. The riser pipe is defective.	Replace.
	i. Undervoltage has occurred.	Check the electricity supply.
4. Frequent starts and stops.	a. The differential of the pressure switch between the start and stop pressures is too small.	Increase the differential. However, the stop pressure must not exceed the operating pressure of the pressure tank, and the start pressure should be high enough to ensure sufficient water supply.
	b. The water level electrodes or level switches in the reservoir have not been installed correctly	Adjust the intervals of the electrodes/level switches to ensure suitable time between the cutting-in and cutting-out of the pump. See installation and operating instructions for the automatic devices used. If the intervals between start/stop cannot be changed via the automatics, the pump capacity may be reduced by throttling the discharge valve.
	c. Checkvalve is leaking or stuck half-open.	Pull the pump and clean/replace the non-return valve.
	d. The supply voltage is unstable.	Check the electrical supply.
	e. The motor temperature is too high.	Check the water temperature.

Troubleshooting

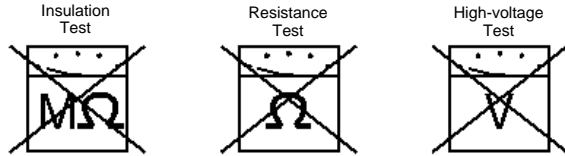

Instruments not allowed:

Note: The use of the following instruments is not allowed during fault finding:



Note: When measuring, use RMS-instruments.

Checking the motor and cable:

<p>1. Supply voltage</p> 	<p>Measure the voltage L1 (RMS) between phase and L2. Connect the voltmeter to the terminals at the connections.</p>	<p>The voltage should, when the motor is loaded, be within the range specified on Page 4, large variations in supply voltage indicate poor electricity supply, and the pump should be stopped until the problem has been corrected.</p>
<p>2. Current consumption</p> 	<p>Measure the current (RMS) while the pump is operating at a constant discharge head (if possible, at capacity where the motor is heavily loaded). For maximum current, see motor nameplate.</p>	<p>If the current exceeds the full load current, there are the following possible faults: Poor connection in the leads, possibly in the cable joint. Too low supply voltage, see item 1 on Page 13.</p>

Environment

During handling, operation, storage and transport, all environment regulations dealing with the handling of hazardous materials must be observed.



When the pump is taken out of operation, it must be ensured that no hazardous material is left in the pump and in the riser pipe, which can be injurious to persons and the environment.

Disposal

Disposal of this product or parts of it must be carried out according to the following guidelines:

1. Use the local public or private waste collection service.
2. If such waste collection service does not exist or cannot handle the materials used in the product, please deliver the product or any hazardous materials from it to your nearest GRUNDFOS company or service center.

Technical Data

Supply Voltage:	1x200-240V +6%/-10%, 50/60 Hz, PE
Operation via Generator:	As a minimum, the generator output must be equal to the motor P1[KW] +10%
Starting Current:	The motor starting current is equal to the highest value stated on the motor nameplate
Starting:	Soft starting
Run-up Time:	Maximum : 2 seconds
Motor Protection:	The motor is protected against: Dry running, overvoltage, undervoltage, overload, overtemperature
Power Factor:	PF= 1
Service Factor:	0.33-0.50A[HP]-1.75 at 230V 0.50-0.75A[HP]-1.4 at 230V 1.0 -1.5C[HP] -1.15 at 230V
Motor Cable:	3 Wire, 12 AWG TEFZEL
Length	Available in 5 ft. increments from 25ft.- 300ft.
Motor Liquid:	Type SML 2
pH Values:	Redi-Flo3: 5 to 9
Liquid Temperature:	The temperature of the pumped liquid must not exceed 104°F.
Note: if liquids with a viscosity higher than that of water are to be pumped, please contact GRUNDFOS	
Discharge Port:	5SQE-NE- 1"NPT 10-15SQE-NE- 1 1/4" NPT 22-30SQE-NE- 1 1/2" NPT
STORAGE CONDITIONS	
Minimum Ambient Temperature:	-4°F
Maximum Ambient Temperature:	+140°F
Freeze Protection:	If the pump has to be stored after use, it must be stored on a frost-free location or it must be ensured that the motor liquid is frost-proof. (The motor must be stored without being filled with motor liquid.)
OPERATING CONDITIONS	
Minimum Ambient Fluid Temperature:	34°F
Maximum Ambient Fluid Temperature:	+104°F
APPROXIMATE DIMENSIONS AND WEIGHT	
Motor Dimensions (MSE3-NE):	
0.33-0.50A[hp]	20.9" length x 2.68" diameter
0.50-0.75B[hp]	20.9" length x 2.68" diameter
1.0-1.5C[hp]	22.3" length x 2.68" diameter
Motor Weights (MSE3-NE):	
0.33-0.50A[hp]	6.0 Lbs
0.50-0.75B[hp]	7.1 Lbs
1.0-1.5C[hp]	8.2 Lbs
Pump End Dimensions:	
Pump Diameter:	2.68"
Pump Diameter, incl. cable guard:	2.91"
Pump End Dimensions(min. and max.):	
5SQE-NE	8.1" to 13.6"
10SQE-NE	8.1" to 14.5"
15SQE-NE	8.1" to 14.5"
22SQE-NE	8.1" to 14.5"
30SQE-NE	8.1" to 11.3"
Pump End Weights(min. and max.):	
All Redi-Flo3 Models	2.2 lbs to 3.5 lbs
Well Diameter (minimum):	3"
Installation Depth (Maximum):	500 feet, below static water level.

Technical Data

PUMP TYPE	HP	VOLTAGE	MAX. AMPS
5SQE03A-90-NE	1/3 A	230V/115V	3.9/7.8
5SQE03A-120-NE	1/3 A	230V/115V	3.9/7.8
5SQE05A-170-NE	1/2 A	230V/115V	4.9/9.8
5SQE05B-210-NE	1/2 B	230V	4.9
5SQE05B-250-NE	1/2 B	230V	4.9
5SQE07B-290-NE	3/4 B	230V	7.6
5SQE10C-340-NE	1 C	230V	7.6
5SQE10C-380-NE	1 C	230V	7.6
5SQE10C-420-NE	1 C	230V	7.6
10SQE03A-100-NE	1/3 A	230V/115V	3.9/7.8
10SQE05A-140-NE	1/2 A	230V/115V	4.9/9.8
10SQE05B-180-NE	1/2 B	230V	4.9
10SQE07B-220-NE	3/4 B	230V	7.6
10SQE10C-260-NE	1 C	230V	7.6
10SQE10C-300-NE	1 C	230V	7.6
10SQE15C-340-NE	1 1/2 C	230V	11.1
15SQE03A-70-NE	1/3 A	230V/115V	3.9/7.8
15SQE05A-110-NE	1/2 A	230V/115V	4.9/9.8
15SQE05B-130-NE	1/2 B	230V	4.9
15SQE07B-170-NE	3/4 B	230V	7.6
15SQE10C-200-NE	1 C	230V	7.6
15SQE10C-230-NE	1 C	230V	7.6
15SQE15C-270-NE	1 1/2 C	230V	11.1
22SQE03A-40-NE	1/3 A	230V/115V	3.9/7.8
22SQE05A-80-NE	1/2 A	230V/115V	4.9/9.8
22SQE05B-110-NE	1/2 B	230V	4.9
22SQE07B-140-NE	3/4 B	230V	7.6
22SQE10C-180-NE	1 C	230V	7.6
22SQE15C-210-NE	1 1/2 C	230V	11.1
30SQE05A-40-NE	1/2 A	230V/115V	4.9/9.8
30SQE05B-80-NE	1/2 B	230V	7.6
30SQE10C-120-NE	1 C	230V	7.6
30SQE15C-160-NE	1 1/2 C	230V	11.1

Technical Data

ACCESSORIES	
PRODUCT	PART NUMBER
CU 300	96422776
Flow Sleeve	96037505
Grease	96037562
Grundfos SPP1 Potentiometer	625468
RediFlo3 Motor Leads - available in 5ft. increments	See price list
25ft	96037428
50ft	96037429
75ft	96037430
100ft	96037431
125ft	96037432
150ft	96037433
175ft	96037434
200ft	96037435
225ft	96037436
250ft	96037437
300ft	96037438
R100 Infrared Remote	625333
HP Infrared Printer 822408	620480